

# WFC- M Series

## Hot Water Fired Single Effect Absorption Chiller

# 1

*Specifications*

*WFC-M100*

*Version 1.0*

(Original/Document)

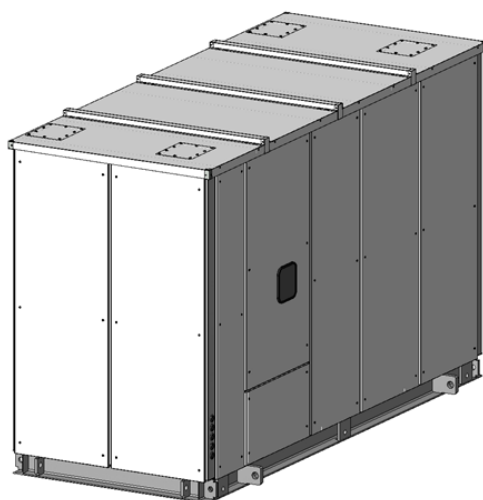

# Contents

	<i>Page</i>
<b>1. Specifications</b>	
1.1 Model designation -----	2
1.2 Multiple module -----	2
1.3 Specification table(WFC-M100) -----	3
1.4 External dimensions & foundation (WFC-M100)---	4
<b>2. Performance Characteristics</b>	
2.1 Cooling performance( WFC-M100) -----	5
2.2 De-rating factor (WFC-M100) -----	6
2.3 Noise criteria (WFC-M100) -----	7
<b>3. Principle &amp; Structure</b>	
3.1 General -----	8
3.2 Cooling cycle -----	8
3.3 Heat balance for WFC-M100(cooling cycle)-----	9
<b>4. Component Identification &amp; Function</b>	
4.1 Chiller assembly (WFC-M100) -----	10
4.2 Component description -----	12

# 1. Specification

## 1.1 Model designation

Example

**W F C - M 100**

Water Fired Chiller

Series

Cooling Capacity RT

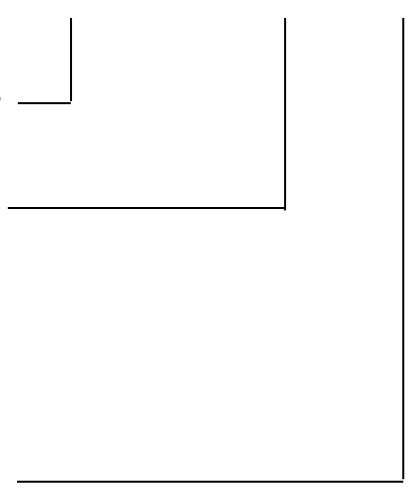

## 1.2 Multiple module combination

Model	Increment RT	Range RT	Note
WFC-M100	100	100 to 500	Cooling only

## 1.3 Specification table (WFC-M100)

Item			WFC-M100	
Cooling capacity			kW	352
Chilled water	Temperature	Inlet	°C	12.5
		Outlet	°C	7.0
	Evaporator pressure loss		kPa	72.6
	Maximum operating pressure		kPa	785
	Flow rate		l/s	15.28
			m <sup>3</sup> /h	55.04
Water retention volume		l.	121	
Cooling water	Heat rejection		kW	854.8
	Temperature	Inlet	°C	29.4
		Outlet	°C	35.4
	Absorber/condenser pressure loss		kPa	66.0
	Coil fouling factor M <sup>2</sup> K/kW			0.086
	Maximum operating pressure		kPa	785
	Flow rate		l/s	34.0
			m <sup>3</sup> /h	122.53
Water retention volume		l.	422	
Heat medium	Heat input		kW	502.8
	Temperature	Inlet	°C	90
		Outlet	°C	80
		Range	°C	70 - 95
	Generator pressure loss		kPa	29.7
	Maximum operating pressure		kPa	785
	Flow rate		l/s	12.36
			m <sup>3</sup> /h	44.50
Water retention volume		l.	250	
Electrical	Power supply		400V 3 Ph 50Hz	
	Consumption	*1	W	680
	Current		A	1.17
Control			On – Off or Proportional	
Dimensions	Width		mm	1,672
	Depth		mm	3,654
	Height		mm	2,200
Weight	Dry		kg	4,940
	Operating		kg	5,740
Acoustics	Noise level dB(A)		56	
Piping Diameter (A)	Chilled water		A	100
	Cooling water		A	125
	Heat medium		A	100
Cabinet and finish			Weatherproof cabinet suitable for indoor or outdoor application comprising silver metallic pre-painted hot dip zinc coated sheet steel exterior panels.	

\*1.Power consumption of chiller only (excluding chilled water, cooling water & heat medium pumps and cooling tower fan)

- Specification are subject to change without prior notice.

- The flow rate of chilled water and cooling water must be stable.

- The allowable flow rate ranges are: Chilled water: 80 to 120% of nominal, Cooling water: 100 to 120% of nominal, Heat medium: 25 to 120%of nominal.

-The Density of Heat Medium is 968.6kg/m<sup>3</sup>, Specific heat is 4.199kJ/kg·K at 85°C at design condition

## 1.4 External dimensions & foundation (WFC-M100)

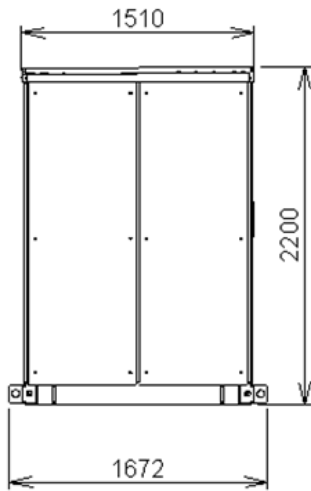

**Front View**

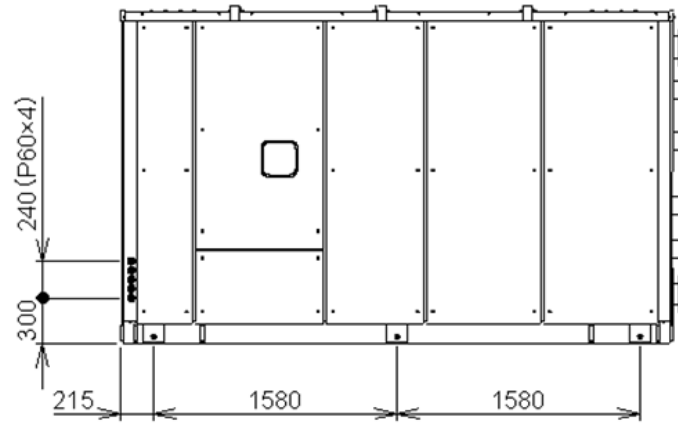

**Right Side View**

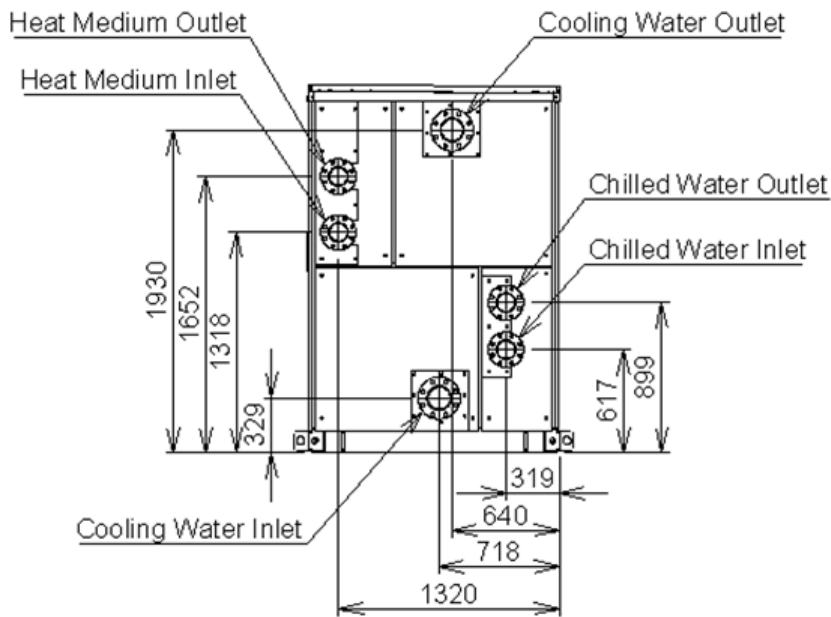

**Rear View**

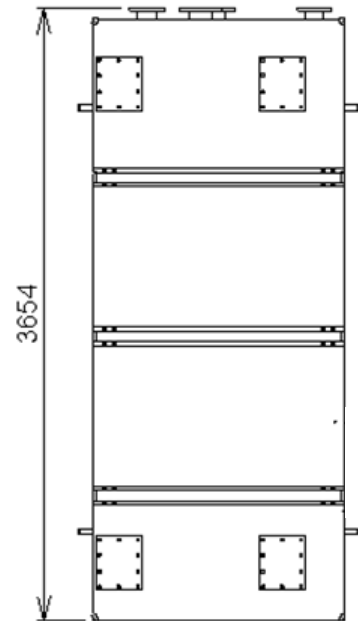

**Top View**

CONNECTION
Chilled water 4" Franged
coolig water 5" Franged
Head medium 4" Franged

## 2. Performance characteristics.

### 2.1 Cooling performance WFC-M100 (typical)

**Note: All other parameters of flow and temperature are considered standard**

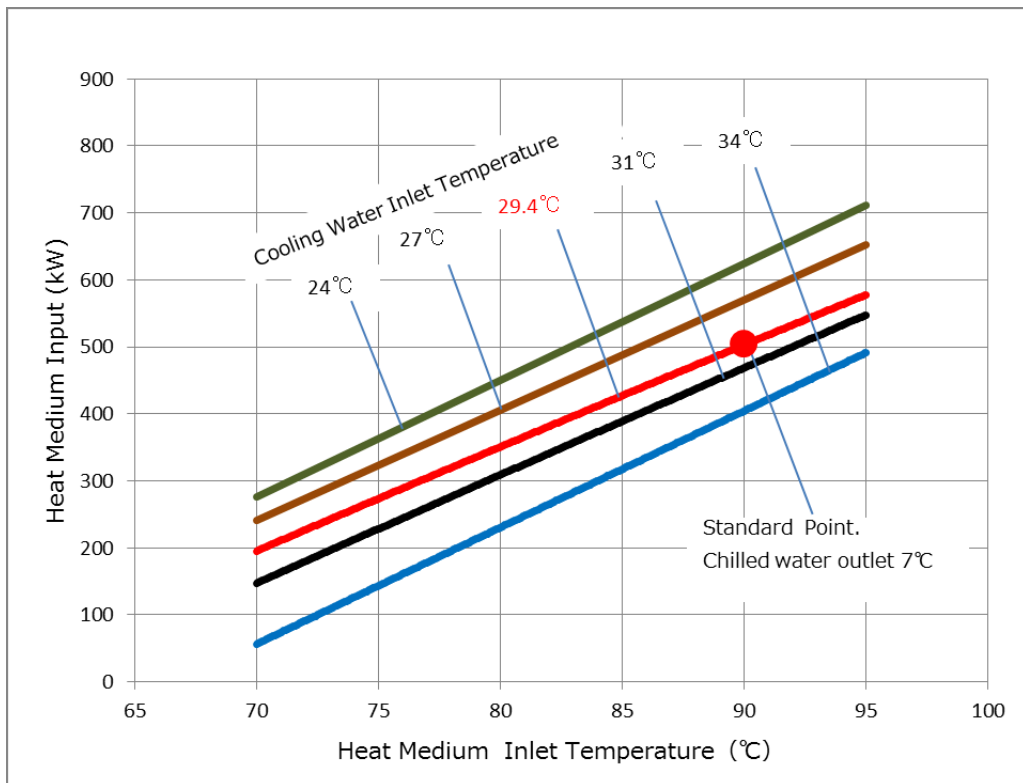
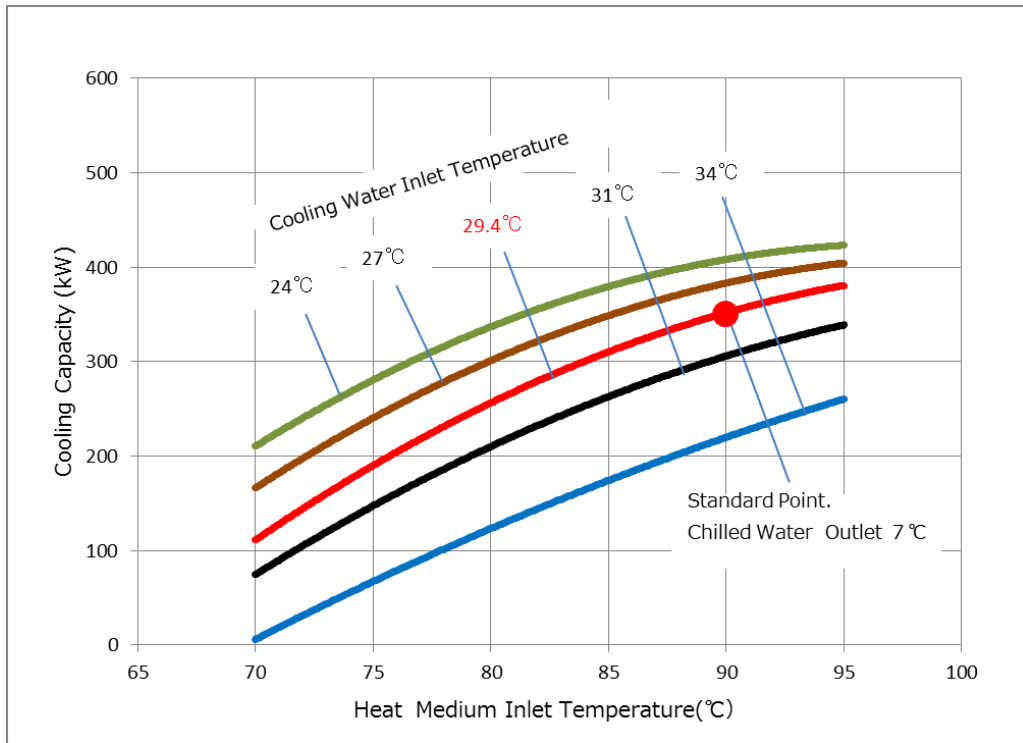

*Curves typify performance characteristics and must only be used for broad reference purpose*

## De-rating factor for reduced heat medium flow (typical)

Note: All other parameters of flow and temperature are considered standard.

### 2.2 De-rating factor (WFC-M100)

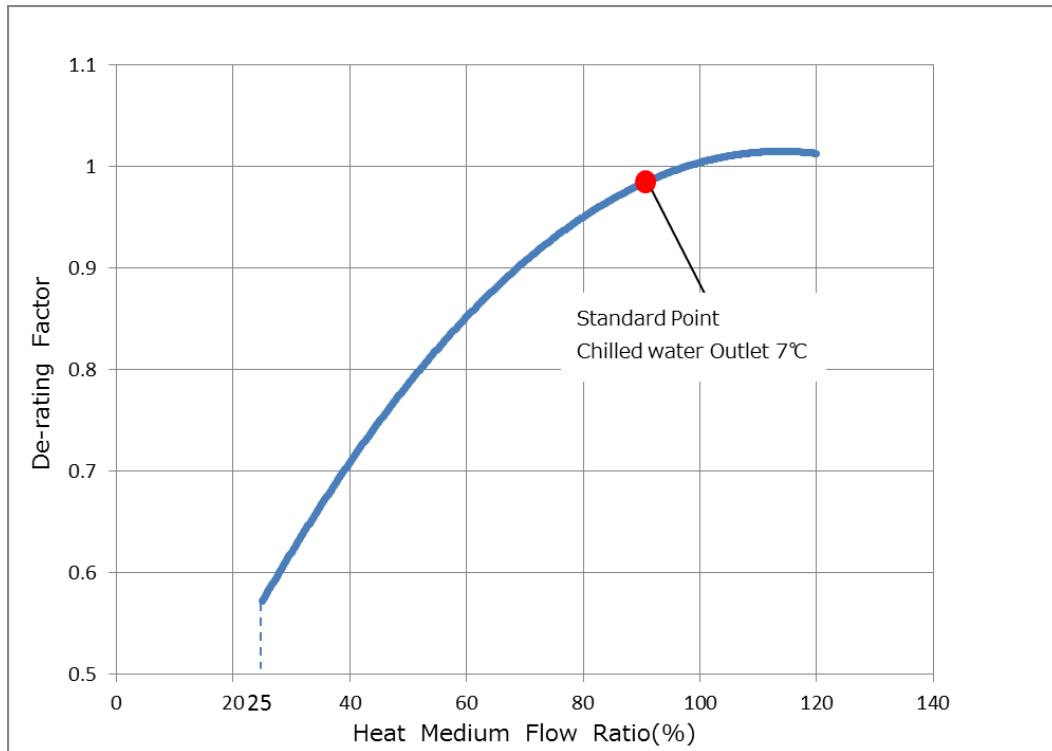

*Curves typify performance characteristics and must only be used for broad reference purpose*

## 2.3 Noise criteria (WFC-M100)

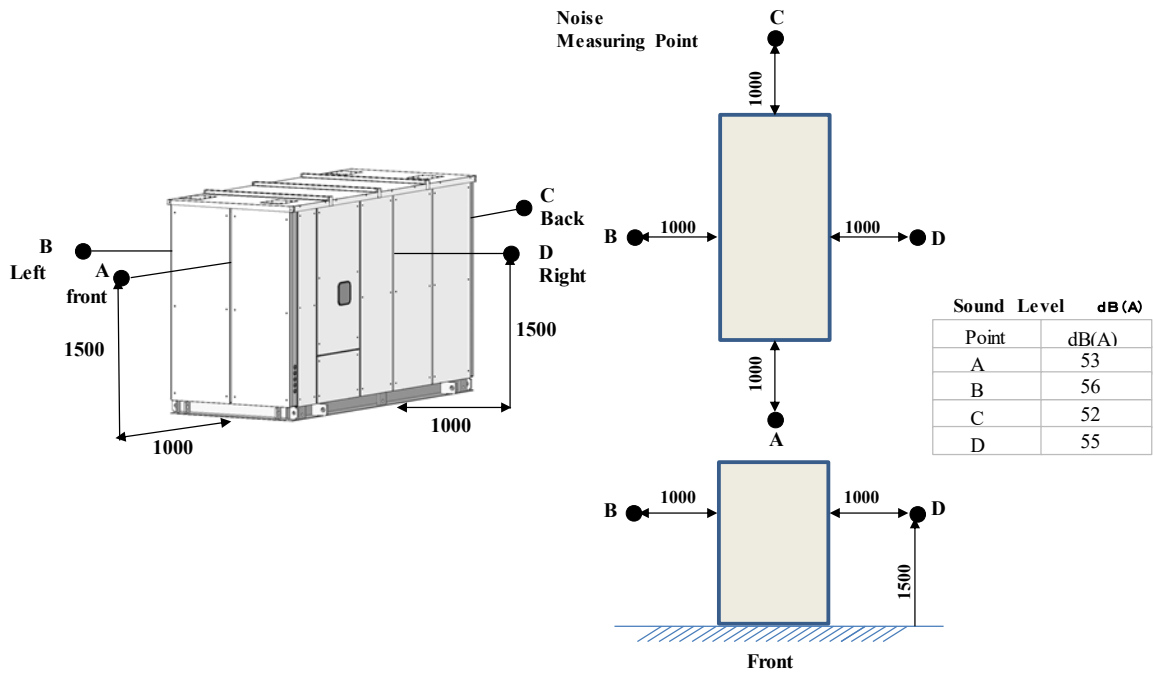

NC curves

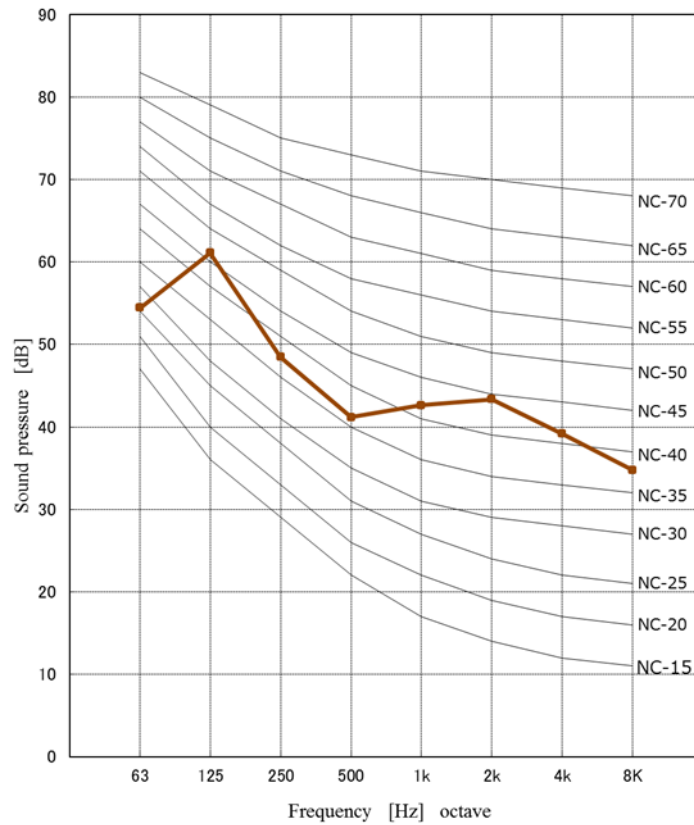

## 3. Principle & Structure

### 3.1 General

WFC-M100 is an absorption chiller (cooling only) which can reduce energy consumption for air-conditioning by utilizing low temperature (70-95degC) hot water, such as CHP cooling water, factory waste heat, and solar water heaters. The WFC-M100 can connect 5 units, adapt up to 500RT cooling capacity.

### 3.2 Cooling cycle.

Referring to the schematic of the cooling cycle as shown in figure1, lithium bromide solution (Dilute Solution) is pumped to the generator (GE) by the solution pump (SP) where it is heated to boiling point by the circulating heat medium. Refrigerant vapor (water vapor) is liberated from solution and flows to the condenser (CON) where it is condensed to a liquid state by rejection of heat to the cooling water from the cooling tower circulating through the condenser coil.

Because partial separation of the lithium bromide and the water in solution has occurred in the process of boiling in the (GE), an increase in concentration takes place and the resultant solution is termed (Concentrate Solution). Accordingly, the concentrate solution flows from (GE) to the heat exchanger (HE), imparting heat to the dilute solution, before arriving at the absorber (ABS) to flow over the surface of the absorber coil.

Since cooling water from the cooling tower is circulating through the absorber coil, a comparatively low vapor pressure is created due to the concentration of the lithium solution, and this is the environment which refrigerant liquid from the condenser encounters as it flows over the coil in the evaporator (EVA). The concentrated solution absorbs refrigerant vapor from the evaporator as the liquid refrigerant changes phase deriving heat of vaporization from the chilled water circulating through the evaporator coil. This results in the production of chilled water.

The concentrate solution returns to a diluted state as refrigerant vapor is absorbed. In its relatively cool condition, it is collected in the (ABS)/(EVA) sump and thereafter forced by (SP) through the (HE) collecting heat from the concentrate solution before returning to the (GE) for boiling again to repeat the cycle.

**Cooling Cycle**

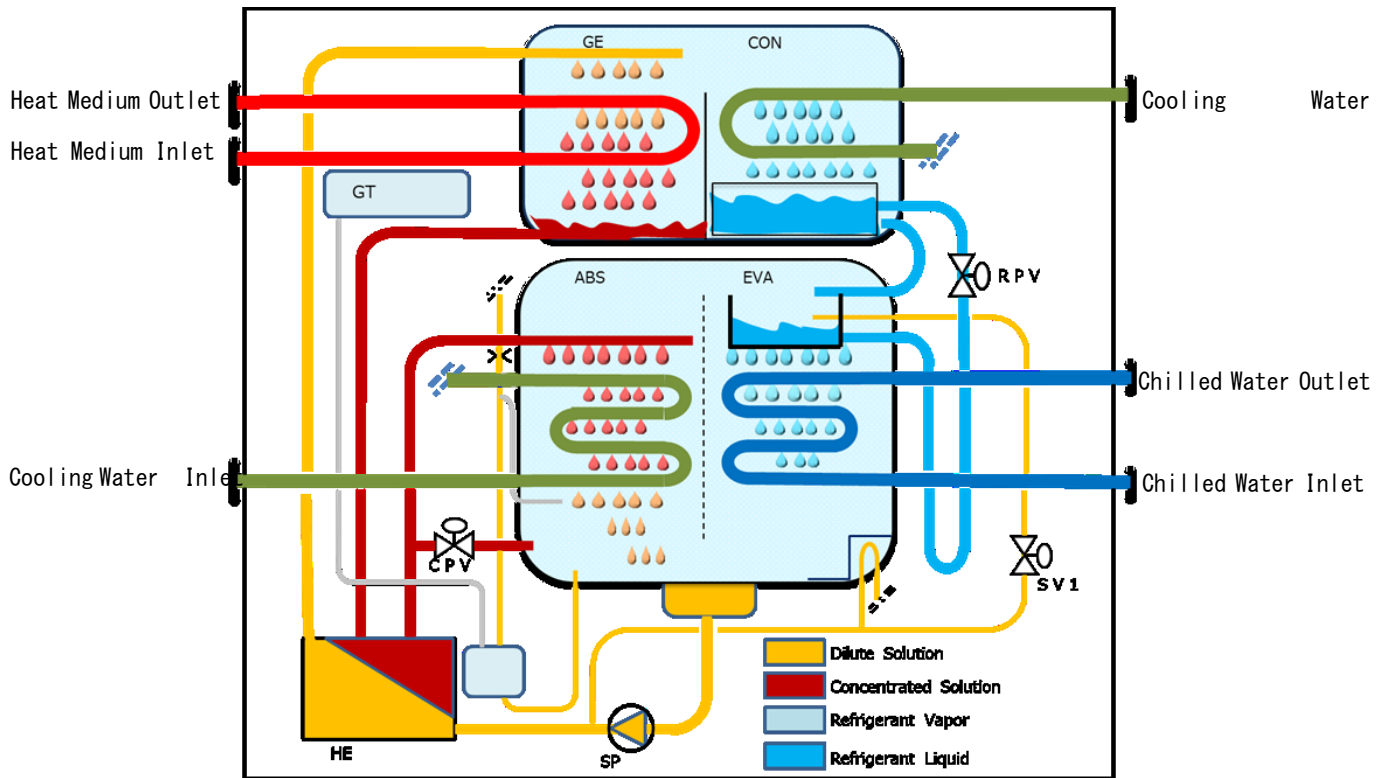

<b>GE:</b>	<b>Generator</b>	<b>EVA:</b>	<b>Evaporator</b>
<b>ABS:</b>	<b>Absorber</b>	<b>CON:</b>	<b>Condenser</b>
<b>SV1:</b>	<b>Solution valve</b>	<b>CPV:</b>	<b>Concentrated proportional valve</b>
<b>SP:</b>	<b>Solution pump</b>	<b>RPV:</b>	<b>Refrigerant proportional valve</b>
<b>HE:</b>	<b>Heat exchanger</b>	<b>GT:</b>	<b>Gas Tank</b>

**Figure1**

**3.3 Heat balance for WFC-M100 (cooling cycle)**

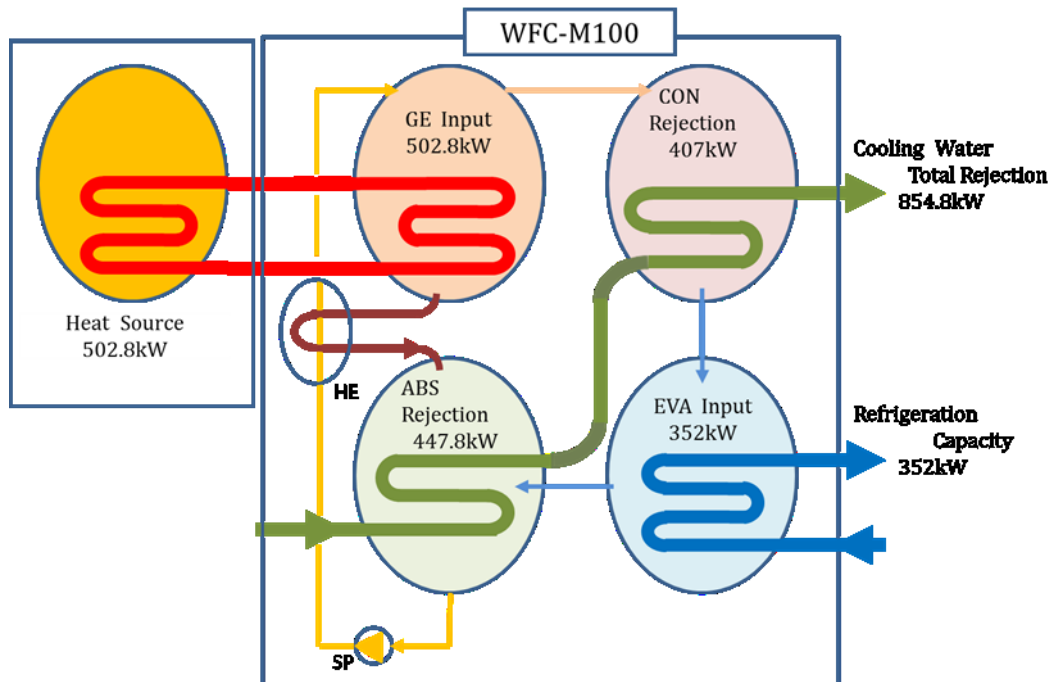

## 4. Component Identification and Function

### 4.1 Chiller assembly (WFC-M100)

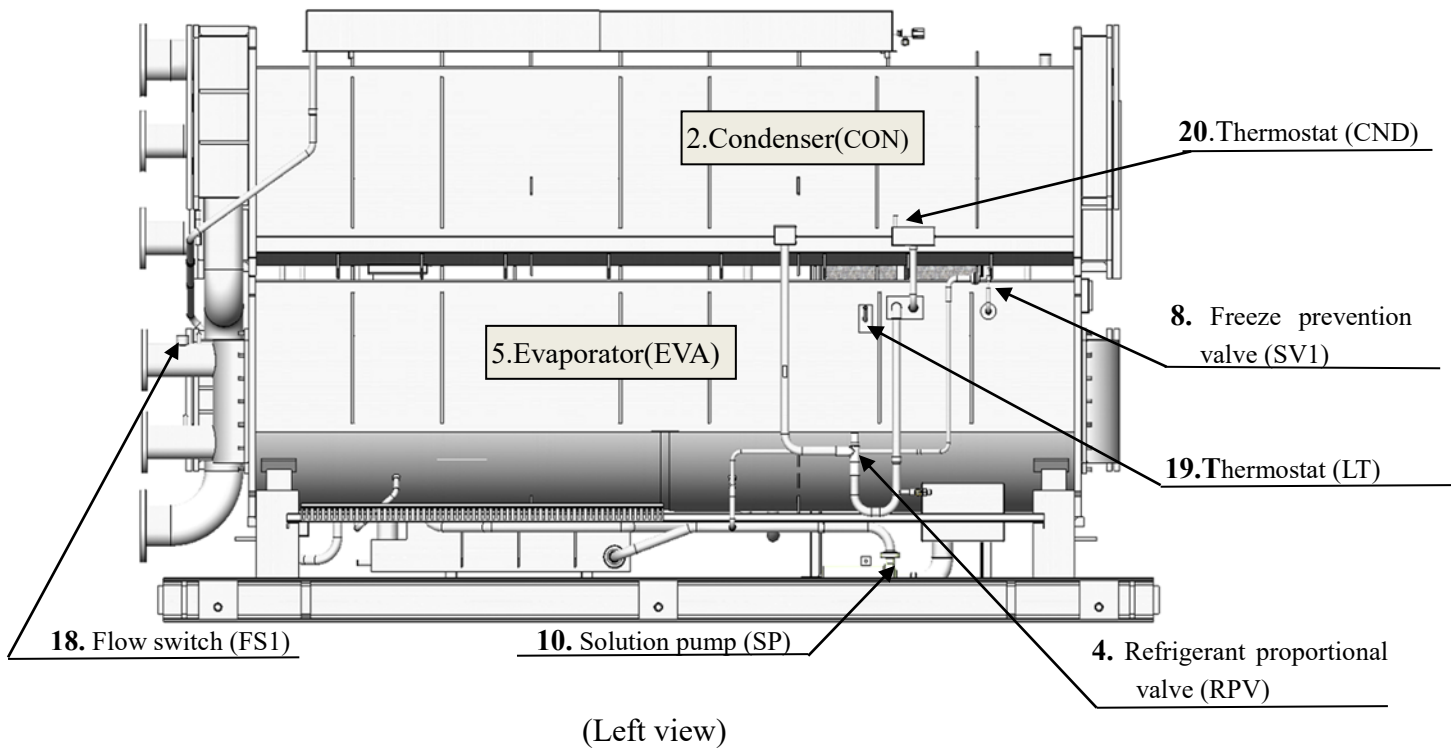
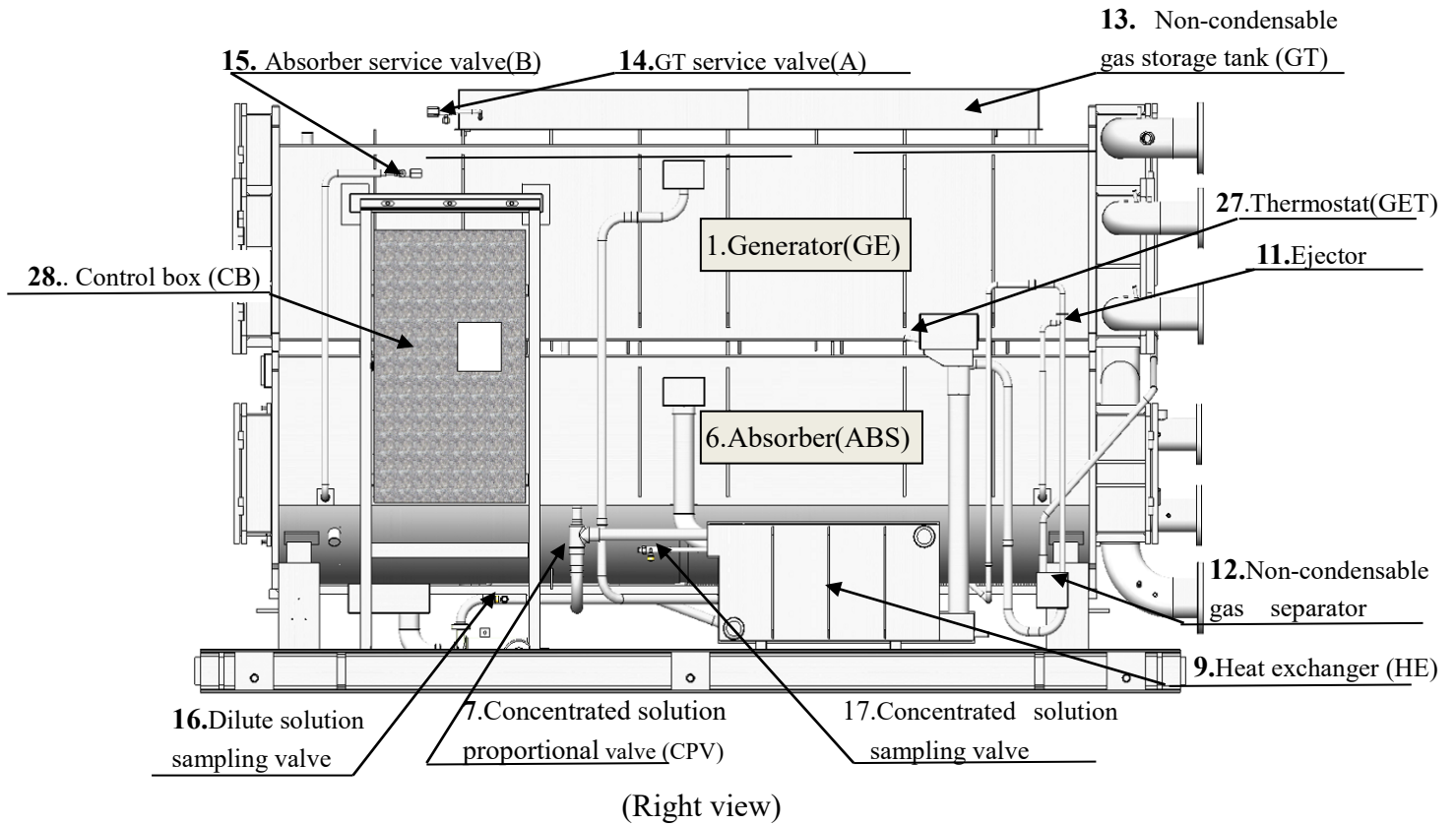

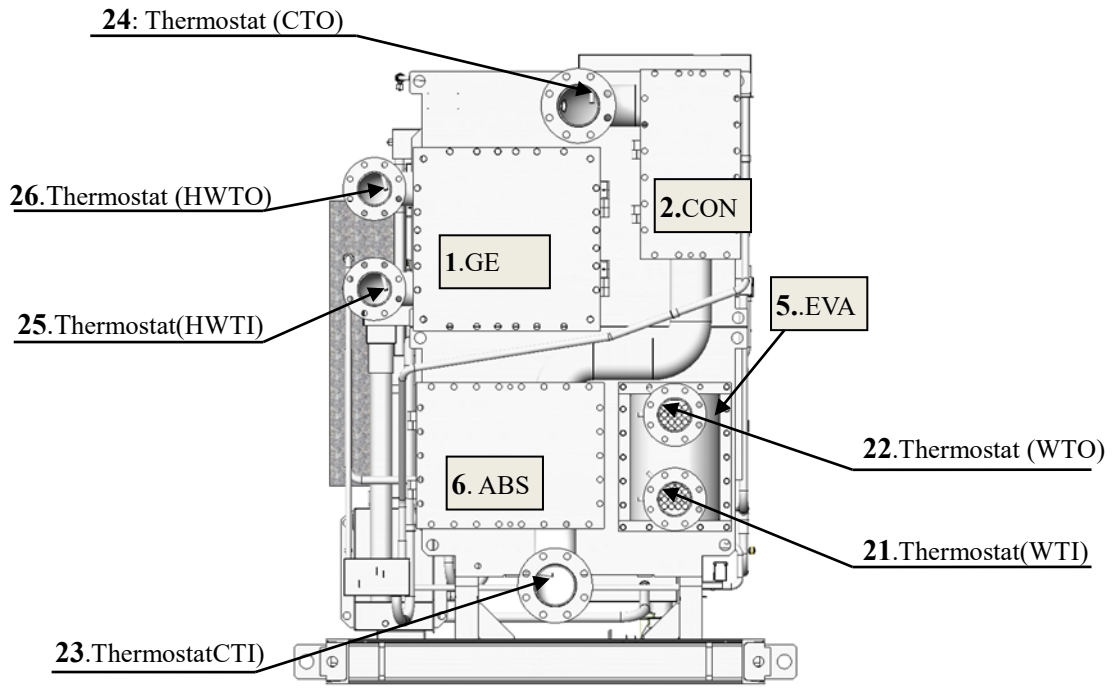



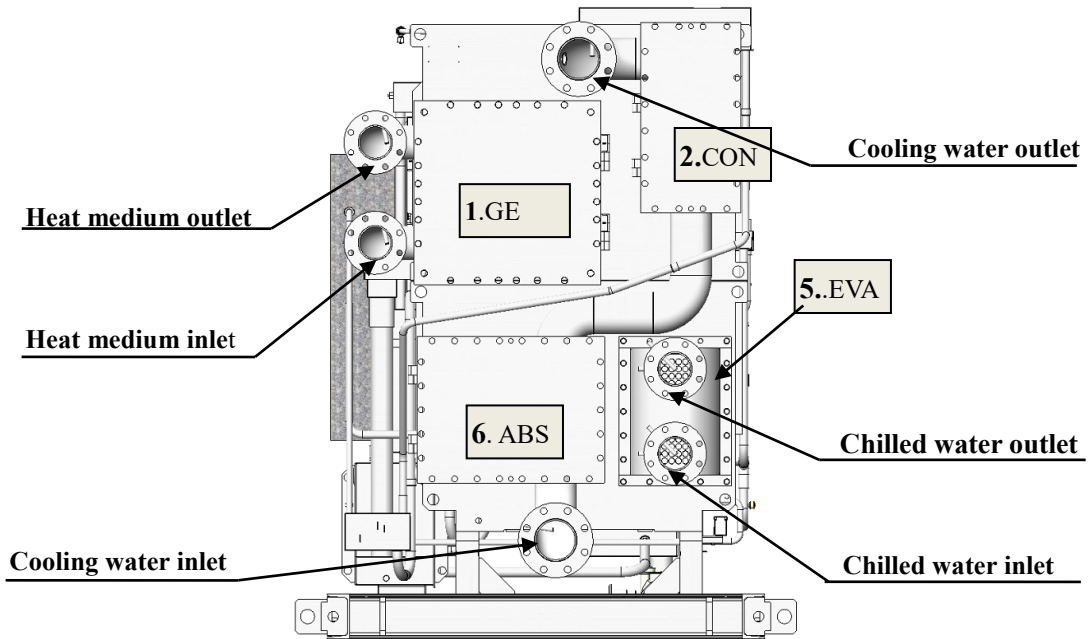



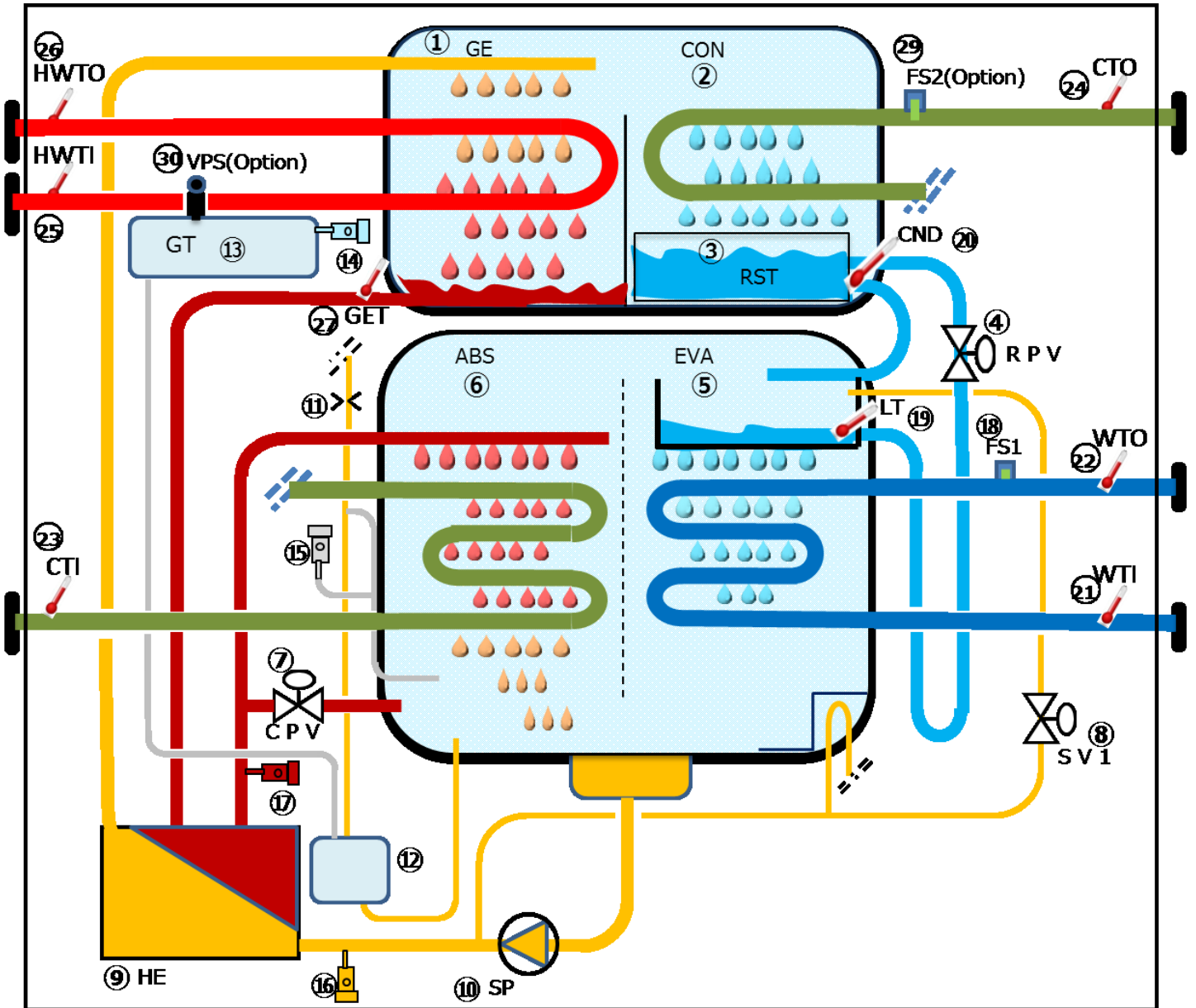

(Rear view)



(Rear view)

## 4.2 Component description



- |  |   |
|--|---|
|  Refrigerant Vapor  |  Dilute Solution       |
|  Refrigerant Liquid |  Concentrated Solution |
|  Chilled Water      |  Cooling Water         |
|  Heat Medium        |   |

No.	Component	Description
1	Generator (GE)	Boils dilute LiBr solution to separate refrigerant from the absorbent
2	Condenser (CON)	Condenses refrigerant vapor to provide liquid refrigerant.
3	Refrigerant storage (RST)	For accumulating liquid refrigerant resulting from the function of the RPV valve.(Inside CON)
4	Refrigerant proportion valve (RPV)	Electromagnetic proportional valve for controlling the storage of liquid refrigerant.
5	Evaporator (EVA)	Heat of evaporation or condensation from the refrigerant is extracted from, or transferred to, the water flowing through the EVA tube.
6	Absorber (ABS)	As refrigerant vapor is absorbed by the LiBr solution, heat of absorption is transferred to the cooling water flowing through the ABS tube.
7	Concentrated solution Proportional control valve (CPV)	When the evaporator temperature falls, CPV valve will open to allow a proportion of the concentrated LiBr solution flowing to the ABS to bypass the tube. When the evaporator temperature increases, CPV will close.
8	Freeze prevention Valve(SV1)	If the operation of CPV does not arrest the fall in temperature of the EVA, SV1 valve will open at 1°C to allow dilute solution to enter the evaporator.
9	Heat exchanger (HE)	Heat exchange between the cool dilute and hot concentrate LiBr solution is facilitated by HE
10	Solution pump (SP)	Dilute LiBr solution is transferred from the ABS to the GE by the SP.
11	Ejector	Using pressured cooled dilute solution as a driving fluid to make lower pressure than ABS to extract non-condensable gas. It is also extractive in similar principle during heating.
12	Non-condensable gas separator	Gases gathered by the auxiliary absorber are separated from dilute solution and transported to the storage tank GT.
13	Non-condensable gas storage tank(GT)	GT retains non-condensable gases accumulating in the absorption circuit.
14	GT service valve (A)	Removal of non-condensable gases from the GT is facilitated by valve (A).
15	ABS service valve (B)	Vacuum service of the ABS/EVA areas of the chiller is afforded by valve (B)
16	Dilute solution sampling valve	Dilute LiBr solution circuit is accessed by the dilute solution service valve.
17	Concentrate solution sampling valve	Concentrate LiBr solution circuit is accessed by the concentrate solution service valve.
18	Flow switch (FS1)	If the chilled water flow rate falls to less than 80% of standard, the operation of the chiller-heater will cease.
19	Thermostat (LT)	Operation of the chiller is responsive to the EVA temperature monitored by LT – see section 4 Electrical & Maintenance.
20	Thermostat (CND)	Condenser refrigerant temp., for judging tube scale formation
21	Thermostat (WTI)	The chilled water outlet temperature is controlled by WTI – see section 4 Electrical & Maintenance
22	Thermostat (WTO)	The chilled water outlet temperature is controlled by WTO – see section 4 Electrical & Maintenance
23	Thermostat (CTI)	The chiller operation is responsive to cooling water inlet temperature monitored by CTI – see section 4 Electrical & Maintenance
24	Thermostat (CTO)	The chiller operation is responsive to cooling water outlet temperature monitored by CTO – see section 4 Electrical & Maintenance
25	Thermostat (HWTI)	Operation of the chiller is responsive to the inlet heat medium temperature monitored by HWTI – see section 4 Electrical & Maintenance.
26	Thermostat (HWTO)	Operation of the chiller is responsive to the outlet heat medium temperature monitored by HWTO – see section 4 Electrical & Maintenance.
27	Thermostat(GET)	GE Concentrated Solution temp., for judging heat medium shortage.
28	Control box (CB)	All operation of the chiller and interface with external controls is provided by the CB
29	Flow switch(FS2) (Option)	If the cooling water flow rate falls to less than 80% of standard, the operation of the chiller will cease.
30	Gas storage tank pressure sensor (VPS) (Option)	Measuring pressure of gas storage tank and give a warning..